

# SAND SEPARATORS

For centrifugal removal of  
sand, silt and gravel from water



FILTRATION SYSTEMS

# SAND SEPARATORS

Time.  
Quality.  
Experience.  
Knowledge.



## Clemons Sand Separators

are ideal for removal of suspended solids and inorganic materials with a specific gravity of 2 or greater. This highly effective system will provide consistent, simple removal of inorganic material down to 75 microns. Easily installed, these carbon steel units are rated to 150 psi with threaded or flanged inlet/outlet connections. Smaller models are designed for vertical installation while larger models are angled and floor or ground mounted.

**Sizing must be within the specified flow range for proper centrifugal action.**

Larger flow separators and custom designed systems are available.

## APPLICATIONS

- Removal of sand, rock, grit and other inorganic contaminants to protect drip and micro-irrigation systems with fine removal down to 200 mesh or 75 microns
- 150 psi standard operating pressure (high pressure systems available)
- Flow ranges from 4 gpm
- Removal of solids with a specific gravity of 2 or greater
- Serves as an excellent prefilter to allow for improved sand media or screen filter performance by removing the gross solids from the water source

## ADVANTAGES

- Sand removal efficiency of 98% of solids down to 200 mesh or 75 microns
- Multiple units in series provide higher efficiencies of filtration
- Units are available in ASME code or non-code construction
- Available with a manual or automatic solids purge valve system
- Special alloys and coatings are available for prolonged life in required applications
- Made in USA



SPECIFICATIONS | SAND SEPARATOR | Angled

Model	Minimum Flow		Maximum Flow		Inlet/Outlet NPT Threaded	Purge Port	Particle Size Maximum
	gpm	m <sup>3</sup> /hr	gpm	m <sup>3</sup> /hr			
R-40LA	200	45	400	91	4"	2"	1 1/2"
R-60LA	365	83	960	218	6"	2"	1 1/2"
R-80LA	800	182	1600	364	8"	2"	1 1/2"
R-100LA	1300	295	2300	523	10"	2"	1 1/2"
R-120LA	2025	460	3400	773	12"	2"	1 1/2"
R-140LA	2975	676	5000	1136	14"	2"	2"
R-160LA	4000	909	6200	1409	16"	2"	2"
R-180LA	5000	1136	7800	1773	18"	2"	2"

SPECIFICATIONS | SAND SEPARATOR | Vertical

Model	Minimum Flow		Maximum Flow		Inlet/Outlet NPT Threaded	Purge Port	Particle Size Maximum
	gpm	m <sup>3</sup> /hr	gpm	m <sup>3</sup> /hr			
R-5V	4	1	10	2	1/2"	1"	3/8"
R-7V	10	2	20	5	3/4"	1"	3/8"
R-10V	18	4	38	9	1"	1"	1/2"
R-12V	26	6	52	12	1 1/4"	1"	1/2"
R-15V	38	9	79	18	1 1/2"	1"	1/2"
R-20V	63	14	120	27	2"	2"	1/2"
R-25V	100	23	180	41	2 1/2"	2"	1/2"
R-30V	125	28	260	59	3"	2"	1/2"
R-40V	190	43	345	78	4"	2"	1/2"

## STANDARD ASSEMBLY INCLUDES:

- Welded carbon steel
- Vertical models include female threaded inlet and outlet connections and a threaded purge port for purging of contaminants or hookup of automatic flush valve
- Angled models include flanged inlet and outlet connections and a threaded purge port for purging of contaminants or hookup of automatic flush valve

## AVAILABLE OPTIONS:

- ASME code
- High pressure
- Special metal alloys and coatings for extended product life
- Ability to disassemble unit for inspection through flanged manways
- Automatic purge valve for flushing of filter
- Wall mount kit on smaller units

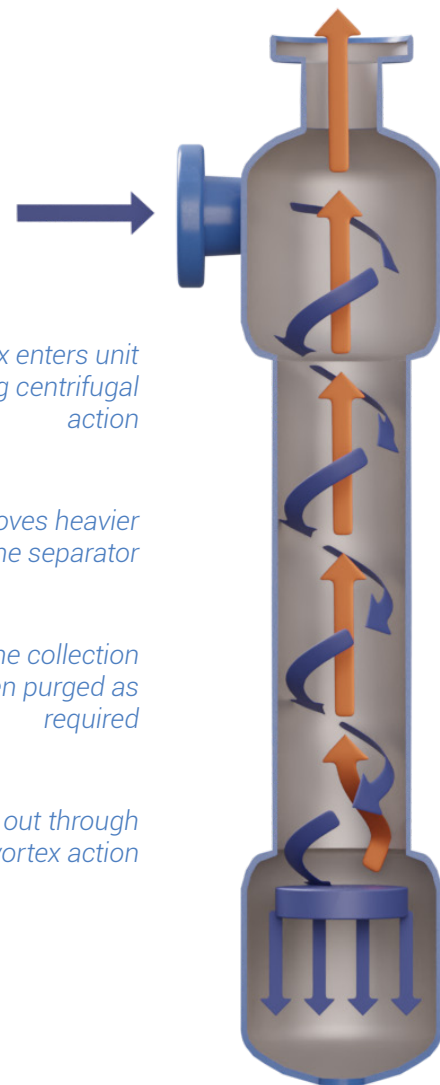

*Liquid/solid mix enters unit tangentially, inducing centrifugal action*

*Centrifugal action moves heavier particles to sides of the separator*

*Solids drop into the collection chamber and are then purged as required*

*Clean water is drawn out through the separator's vortex action*

DIMENSIONS   Angled											
Model	A	B	C	D	E	F	G	H	I	J	K
R-40LA	48 1/2"	46 1/2"	46 1/2"	16 11/16"	16"	7 1/2"	19"	4"	6 5/8"	12"	80"
R-60LA	63"	59 1/2"	60 3/8"	20 1/2"	20 3/4"	10 1/2"	22"	5 1/4"	10 3/4"	16"	106 1/4"
R-80LA	71"	65"	66"	21 3/4"	22 5/8"	12"	24 1/2"	5 5/8"	12 3/4"	18"	114"
R-100LA	78"	71"	72 3/4"	21"	24 1/2"	13"	29"	7"	16"	22"	123 1/2"
R-120LA	102"	75 1/4"	76 1/2"	23 3/4"	26 5/8"	14 1/4"	32"	8 1/8"	18"	26"	139"
R-140LA	102 1/2"	85 3/8"	86 5/8"	24 1/2"	27 3/4"	12"	33 1/2"	9"	20"	28"	152 1/2"
R-160LA	108"	89 1/4"	90"	24 3/8"	29"	12"	33 1/2"	9"	24"	30"	160"
R-180LA	118 1/2"	98 1/4"	100 1/4"	27"	33 5/8"	15"	34 1/2"	11"	28"	36"	177"

DIMENSIONS   Vertical				
Model	A	B	C	D
R-5V	21 1/2"	6"	2 3/8"	2 1/2"
R-7V	21 1/2"	6"	2 3/8"	2 1/2"
R-10V	30 1/2"	6"	3 1/2"	2 3/4"
R-12V	30 1/2"	6"	3 1/2"	3"
R-15V	30 1/2"	6"	3 1/2"	3 1/8"
R-20V	38"	8"	4 1/2"	3 5/8"
R-25V	43 3/4"	10"	4 1/2"	4 1/2"
R-30V	47 1/2"	10"	5 9/16"	5"
R-40V	49"	12"	6 5/8"	6"

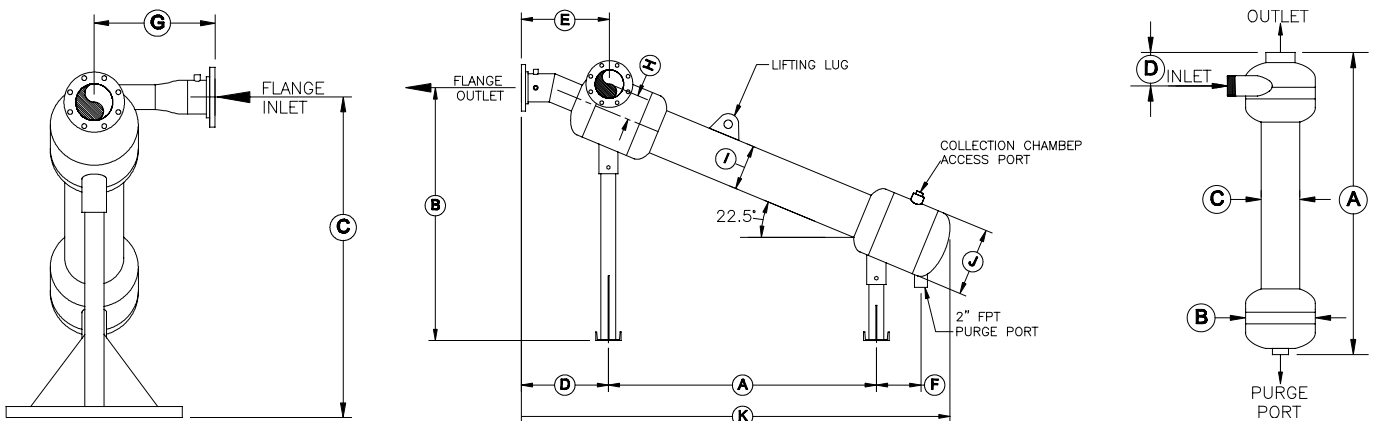
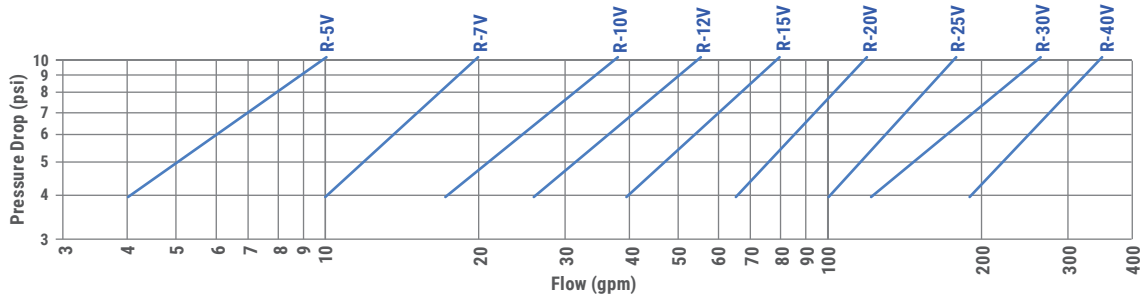
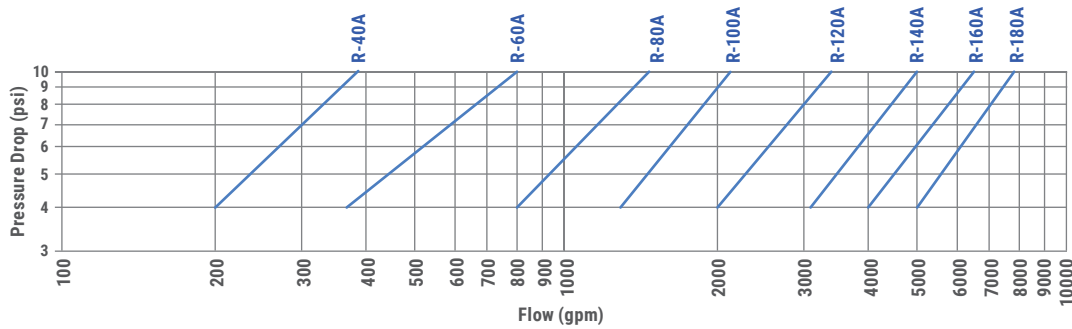

Made in USA

Phone: +1 (208) 345-2525  
 Toll-Free: +1 (800) 635-5975  
 Fax: +1 (208) 345-2143

**Clemons**  
 www.clemonssales.net